

Lumalarm LED BACK UP ALARM



Multi-function back up alarm.

With flashing amber LED warning lights.



Feature

- Multi-functional back up alarm
- Night silent
- 200 lumen amber LED
- Wraparound LED lens
- ABS plastic housing
- Epoxy encapsulated electronics



Benefit

With flashing amber LED warning lights.
Alarm can be disengaged when in sound sensitive areas. Flashing amber LED warning stays on warning pedestrians of vehicle presence. Provides bright visual warning of vehicle backing up in addition to audible alarm.
Flashing amber LED warning is visible beyond 180° on either side of back up alarm, providing added safety.
Robust construction for heavy duty applications.
Electronic components are protected against environmental elements.

Specifications

Lumens:	200
Operating Voltage:	12 - 24Vdc
Operating Current:	500mA @ 12Vdc 250mA @ 24Vdc
Temperature Range:	-57°C to +67°C
Weight:	7.0oz (200g)
Housing:	Black ABS
Lens:	PMMA Clear Optical Grade
Connection:	5 Wires
Compliance:	SAE J994

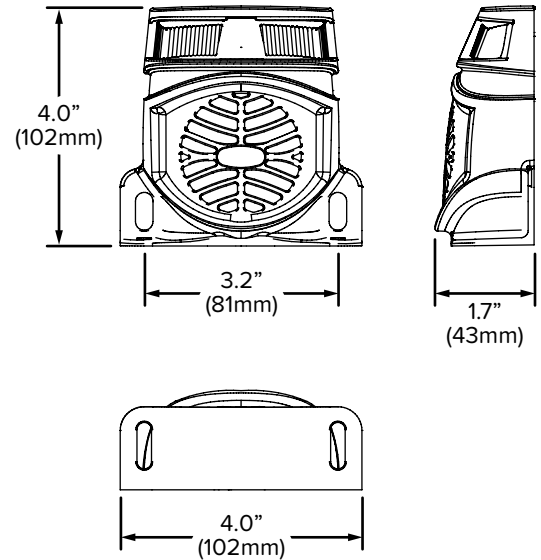

Part #	dB Rating	Operating Voltage
52050	87dB	12 - 24Vdc
52051	97dB	12 - 24Vdc
52052	107dB	12 - 24Vdc

Modes	Functions	LEDs					Alarm	LEDs
		Red	Orange	Green	White	Black		
Normal Alarm	Vehicle Backing Up - Reverse	+				-	✓	✓
Night Silent	When Park Light ON	+	+			-		✓
Override Night Silent	When Fog Light ON with Park Light	+	+	+		-	✓	✓
Alarm Only	When Flashing Not Needed	+			+	-	✓	
Flashing Amber Only	When Dashboard Switch ON	+		+		-		✓

+ 12Vdc - Ground



For more lighting and electronic solutions, please check out our catalogue.