

# XWL-813 5000 Series | HDM LED WORK LIGHT | 5000 LUMENS

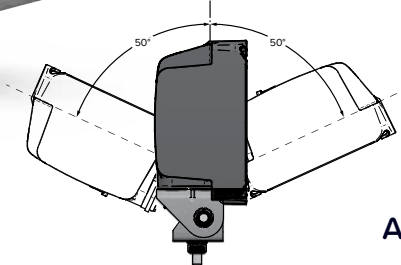

**HEAVY DUTY  
MOUNT**



## Heavy Duty Mount.

Super tough stainless steel mounting brackets and hardware.

Allows 50° tilt forwards & backwards.



### Feature

- Die cast aluminum housing and polycarbonate lens
- IP68 & IP69K
- Constant current circuit draw
- 3 beam patterns
- Built-in vibration dampeners
- 50,000+ hours LED service life



### Benefit

- Virtually unbreakable.
- Will withstand dust, dirt, sand, and water submersion.
- Light does not dim even if voltage fluctuates.
- Get light where it's needed most.
- Reduces the intensity of shock and vibration.
- Long lasting investment, quality product.



[www.hamsar.com](http://www.hamsar.com)



### Specifications

Operating Voltage:	12 - 24Vdc
Operating Current:	4.2A @ 12Vdc 2.1A @ 24Vdc
Power Consumption:	50W
Temperature Range:	-40°C to +60°C
Ingress Protection:	IP68 & IP69K
Weight:	3.5lbs (1.6kg)
Housing:	Die Cast Aluminum - Black E-Coat
Lens:	Automotive Optical Grade Hard-Coated Polycarbonate
Connection:	Tyco or Deutsch
Polarity:	Reverse Voltage Protected
Vibration Resistance:	10-500Hz @ 5Grms
Mounting:	U-Bracket
EMC Rated:	EMC EN 13309: 2010

Part #	Beam Pattern	Lumens	Operating Voltage
--------	--------------	--------	-------------------

#### Tyco Connector

81665	Spot	5000	12 - 24Vdc
81666	Medium Flood	5000	12 - 24Vdc
81667	Hybrid	5000	12 - 24Vdc

#### Deutsch Connector

81668	Spot	5000	12 - 24Vdc
81669	Medium Flood	5000	12 - 24Vdc
81670	Hybrid	5000	12 - 24Vdc

#### Accessories

98195	Easy Grip Handle - Black   Blue   Orange
-------	--

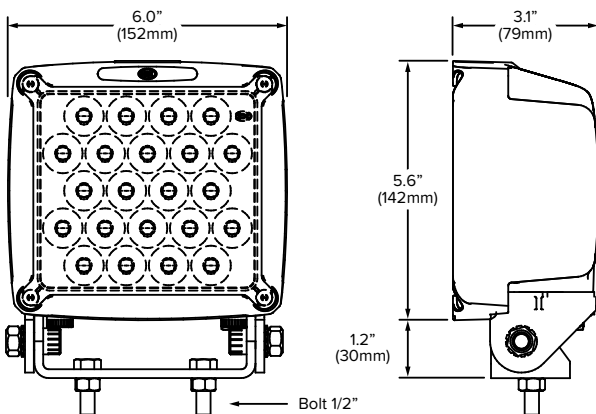

### Beam Patterns

#### Spot Pattern

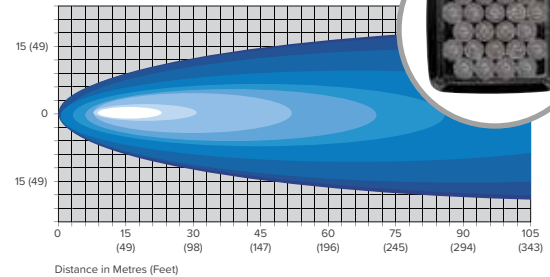

#### Medium Flood Pattern

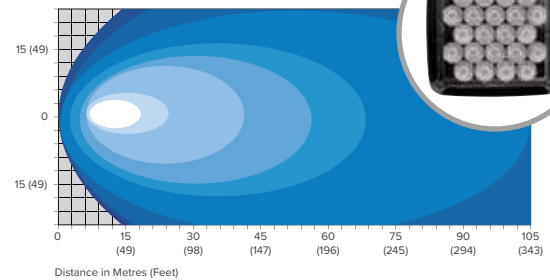

#### Hybrid Pattern

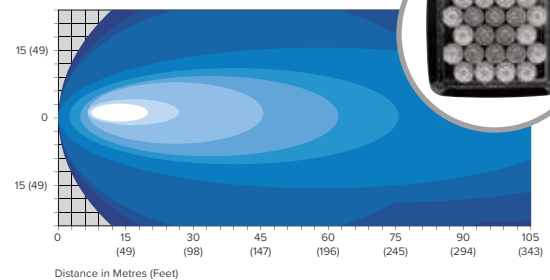

### Connector Options

#### Tyco

#### Deutsch

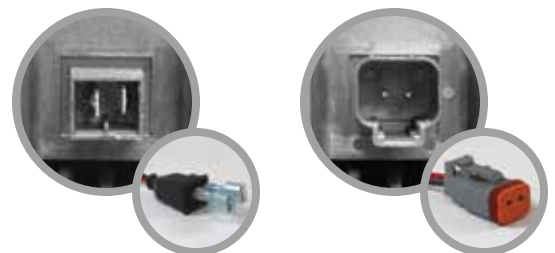

For more lighting and electronic solutions, please check out our catalogue.