

# XWL-812 | Red LED Safety Light

## SAFETY LIGHT | 150 LUMENS



Designed with safety and awareness in mind.



### Feature

- The red LED forklift light is visible in warehouse environments
- Beam precedes vehicle by 16 feet (5 metres)
- Round beam pattern
- Versatile & compact design
- 12 - 48Vdc



### Benefit

Ideal for forklifts, load trucks, AGVs and other industrial vehicles used in close proximity to pedestrians. Provides visual warning to alert pedestrians of approaching machinery before it is heard or seen. Red round shape projected to the ground, alerts pedestrians of proximity to moving vehicle. Only 4" x 4" and lightweight, mounts easily on the front or back of vehicle. Can be used on heavy duty vehicles.

**Specifications**

Operating Voltage:	12 - 48Vdc
Operating Current:	0.8A @ 12Vdc 0.2A @ 24Vdc
Power Consumption:	10W
Temperature Range:	-40°C to +85°C
Ingress Protection:	IP67 & IP69K
Weight:	1.5lbs (0.7kg)
Housing:	Die Cast Aluminum - Black E-Coat
Lens:	Automotive Optical Grade Hard-Coated Polycarbonate
Connection:	Tyco or Deutsch
Polarity:	Reverse Voltage Protected
Vibration Resistance:	10-500Hz @ 5Grms
Mounting:	U-Bracket
EMC Rated:	EMC EN 13309: 2010

**Connector Options**

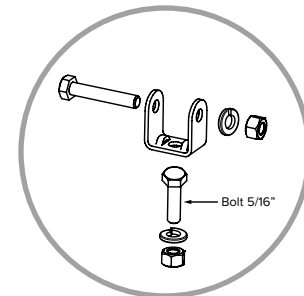
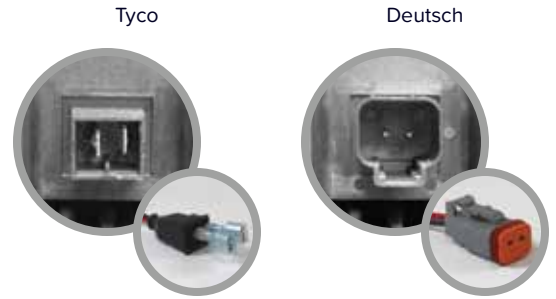

**U-Bracket**

Part #	Connector	Lumens	Operating Voltage
82296/B	Tyco	150	12 - 48Vdc
82296/C	Deutsch	150	12 - 48Vdc

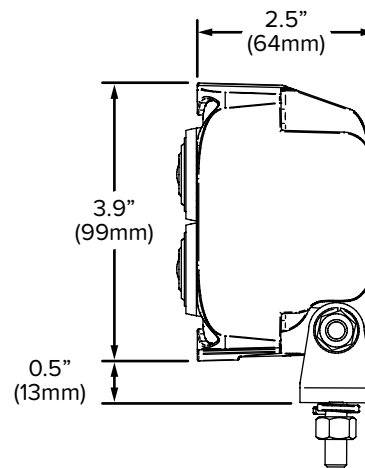
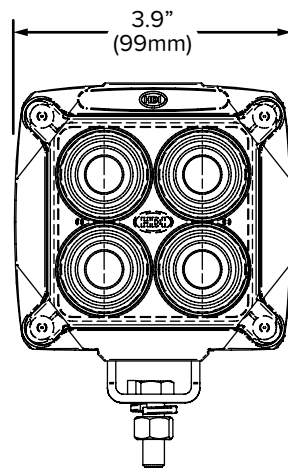

For more lighting and electronic solutions, please check out our catalogue.